

INSTALLATION OF: PLANKS - FLOATING

There are 3 main methods for installing Ted Todd wood floor planks.

- Fully-Bonded (Glued down)
- Floating
- Nailed down
- Decide very early in the project what is the preferred installation method with due regard to the subfloor, the type of wood floor being installed and the end-use of the area of installation.
- Always check with the end-user that the correct product has been delivered and that they are happy with the grade and visual appearance of the floor. Open several packs at a time and mix the boards to ensure a good degree of board selection so the installation is visually well-balanced.
- Agree on the laying pattern and the orientation of the planks within each room. Normally the longest run of the room is the direction the planks should be laid, but do consider other factors such as lighting, windows and doors.
- Agree on the width balance of the planks in the room too.
- All installations should comply with BS8201.

4.1 Site Checks

Before commencing installation ensure the requirements have been met for:

- Jobsite Conditions, Moisture Testing and Acclimatisation (Chapter 1A, 1B and 1C).
- Ambient temperature range of 16 to 24°C.
- Ambient relative humidity of RH of 45 to 65%
- Subfloors, see Chapter 2 for a full check list.

4.2 Acceptable Sub Floors

- For Wood based subfloors there should be no more than 12%MC and should be no more than +/- 2% Moisture Content difference to the Wood Flooring.
- Concrete / Screed. For concrete screeds moisture content should not exceed 2% (calcium carbide measure) or RH of 65%. Anhydrite-based screeds with MC of no more than 0.5% (0.3% with UFH).
- Joists - (must be Boarded by Plywood or OSB if flooring is floated) 20mm products only, always use a Sisalkraft type Builders Paper as a moisture barrier.
- Tiles – when flat.
- Subfloors must be Dry and Flat. See Chapter 2.

Note: It is not recommended to float engineered flooring over a subfloor that is actively moving or unstable, you can however float over a subfloor that is slightly uneven or flexible. Engineered wood flooring is designed to expand and contract with changes in temperature and humidity, and a moving subfloor can prevent this movement, potentially leading to damage or buckling. While some movement is inherent in floating floors, excessive movement from the subfloor can cause problems.

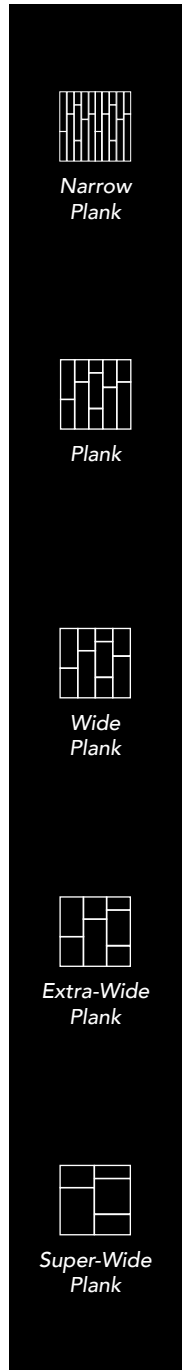

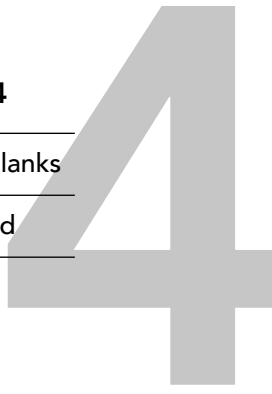

INSTALLATION OF: PLANKS - FLOATING

4.3 Installation Guidelines, All Planks installations.

- Choose a starting wall according to the most aesthetically or architecturally important elements in the room, taking into consideration fireplaces, doors, cabinets and transitions, as well as the squareness of the room. The starting wall will often be the longest unbroken wall in the room but do consider all other factors such as lighting. Do consider the width balance of the planks across the room too.

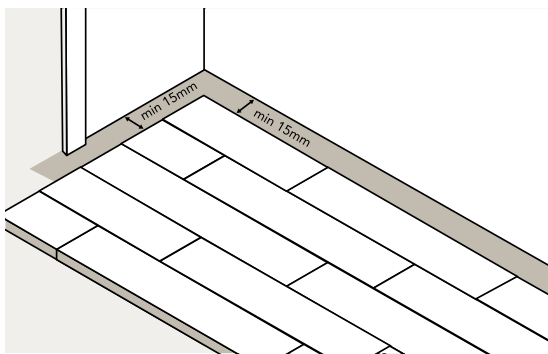

Figure 1: Leave a minimum of 15mm around the perimeter and all architectural details and obstructions

- Where possible, expansion gaps must be left though doorways/archways and covered with T-sections to break up large areas of installation. A minimum expansion space of 15mm must be left around the perimeter and all vertical obstructions.
- Remember that the floor must be allowed to expand and contract under the thresholds, skirting and other joint covers.

- Door architraves can be undercut to allow for the floor planks to fit underneath and still permit the expansion and contraction of the planks.
- Consider how the perimeter expansion gaps will be covered after installation. Skirting boards or scotia and other profiled shapes are available for this. They must be installed to allow for movement of the flooring planks below.
- Plan to distribute lengths of planks in a fashion where the end joints are randomly-staggered. Avoid "H" patterns (as below) and other discernible patterns in adjacent runs. Stagger end joints at least three times the width of the boards, as product allows.
- Use the offcut from the end of one row to start the next row.

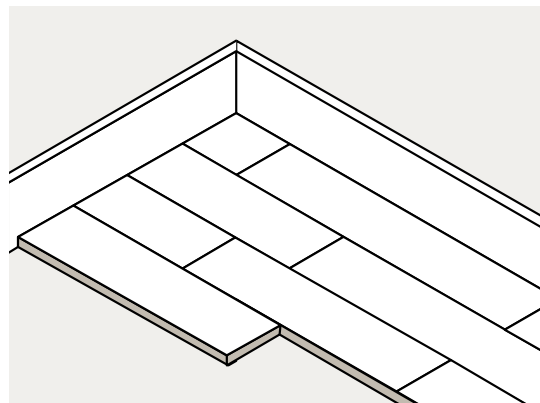

Figure 2: shows a typical arrangement of planks, using one offcut to start a row and the other to finish.



Narrow Plank



Plank



Wide Plank



Extra-Wide Plank



Super-Wide Plank

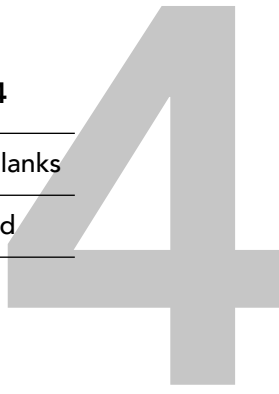

INSTALLATION OF: PLANKS - FLOATING

- Consider the width balance of the planks across the room. Plan ahead to ensure that opposite walls have approximately half-width planks to avoid narrow off-cuts which are difficult to install and can look odd.
- For 2 and 3-layer engineered flooring there is frequently a bow within the board. This can be up to 1.5% of the board length and therefore it is important to ensure that the first rows are laid with the boards being interlocked to around half of the length. This will ensure the boards lie flat and permit installation.
- The Ted Todd Fidbox monitoring is recommended to be installed on installations with UFH. (See Chapter 13 for extra guidelines relating to installations with UFH.)

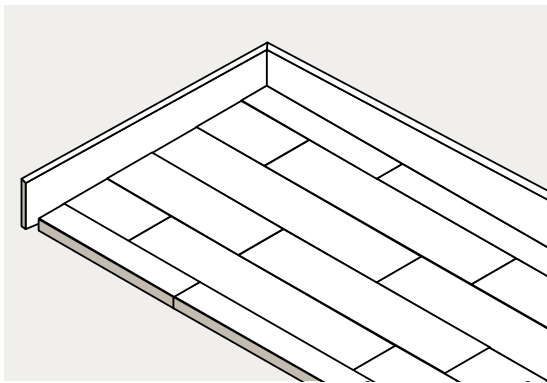

Figure 3: Plan ahead to ensure that opposite walls have approximately half-width planks

4.5 Installation Guidelines, Ted Todd Planks.

Floating method.

- Do not float engineered floors where the dimension of an installation area exceeds 6m in width and 10m in length. If these dimensions are exceeded, please glue down (fully bond) the flooring using Ted Todd's MS Flex adhesive, as per Chapter 3 of the Ted Todd Installation Guide.
- Do not allow any fixed furniture items such as kitchens, cupboards and any other fixed joinery to be installed over a floating floor installation. This is because any item that is screwed into or through a floating floor will restrict the natural "floating" expansion and contraction of the wood floor planks.
- Ensure a suitable wood-floor underlay with DPM or vapour retarder has been applied under the flooring planks, unless with the use of under floor heating.
- Only use an approved wood floor underlay. Low density underlays, or those with a low compressive strength, should not be used as they will allow flexing of the planks and not offer the necessary support to the T&G joints.



Narrow Plank



Plank



Wide Plank



Extra-Wide Plank



Super-Wide Plank

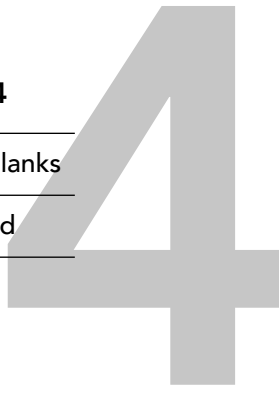

INSTALLATION OF: PLANKS - FLOATING

4.5.1 Laying out and getting started.

All Ted Todd Plank flooring can be installed using the Floating method over acceptable subfloors that are within room dimension guidelines. See Chapter 2 and Section 3.2 above.

- Once the general layout of the floor planks in the room has been agreed upon, (Sections 3.0 to 3.3 above) an appropriate underlay should be chosen. The main factors in the choice of underlay, and the recommended Ted Todd choices are as per the table below:

FACTOR	MEASUREMENT	BEST CHOICES OF TED TODD
Noise	dB Impact sound transmission. Broadly related to thickness	Amphion(28dB) Bond 5mm (26dB) Blue (23dB) Olympia (23dB)
Moisture	Moisture barrier. Most Ted Todd Underlays have built-in moisture barriers	All except Bond and Amphion. Can use the Moisture block foil
Levelling	Thickness can absorb small sub-floor surface variations	Blue (5mm) Amphion (5mm) Bond (5mm) Olympia (3.6mm) Green (3.2mm)
Heat insulation	Tog value (want high, insulate from cold)	Blue (1.8) Bond 5mm (0.83)
UFH	Tog value. (Want low to aid heat transmission)	Green (Tog 0.1) Yellow (Tog 0.4)
Cost	£, Per Roll and per M ² . Check latest Ted Todd price list.	Red, exceptional value £/m² Plus look at Bond total installation costs.
Ease of installation	Roll size, weight, packing, overlaps, cutting lines	Blue (folded, with overlap) Bond (self-adhesive)
Compression / longevity	Density. How it performs and supports the T&G, effects of compression. Quality, weight.	Green (1000kg /m²) Olympia (800kg /m²)

Narrow Plank



Plank

Wide Plank

Extra-Wide Plank

Super-Wide Plank

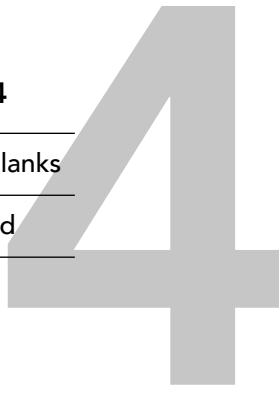



INSTALLATION OF: PLANKS - FLOATING

- The underlay should be installed first, and all seams taped with aluminium tape, or using the overlap if included on the underlay, to ensure the continuity of the moisture barrier.
- Following the guidelines in 3.0 to 3.3 above start laying out the planks on top of the underlay.
- Snap a working line parallel to the starting wall, the width of the board, plus the tongue and recommended expansion space.
- Use Spacers between the wall and the first row of flooring planks allowing for any taper or unevenness in the wall. This helps maintain the correct expansion gap and allows for the first row to be supported when installing or knocking together the T&G of following rows.
- The planks should be glued together using Ted Todd T&G adhesive. This should be applied in an even bead, to the top of each tongue on both the long side and short end. The planks should then be pushed together to make a tight joint with its neighbouring plank.
- A knocking block may be used to tap the boards together to tighten the joints. Be careful not to hit the boards too hard as this may cause other, already-joined boards to separate. A tensioner strap may be used to hold the boards in place, tightly together, whilst the adhesive dries. MS Flex full curing time is 36 to 48 hours.
- (NB the T&G's should only be glued together in Floating installations. Never in a fully-bonded installation as this would affect the natural expansion and contraction of the fully bonded planks).

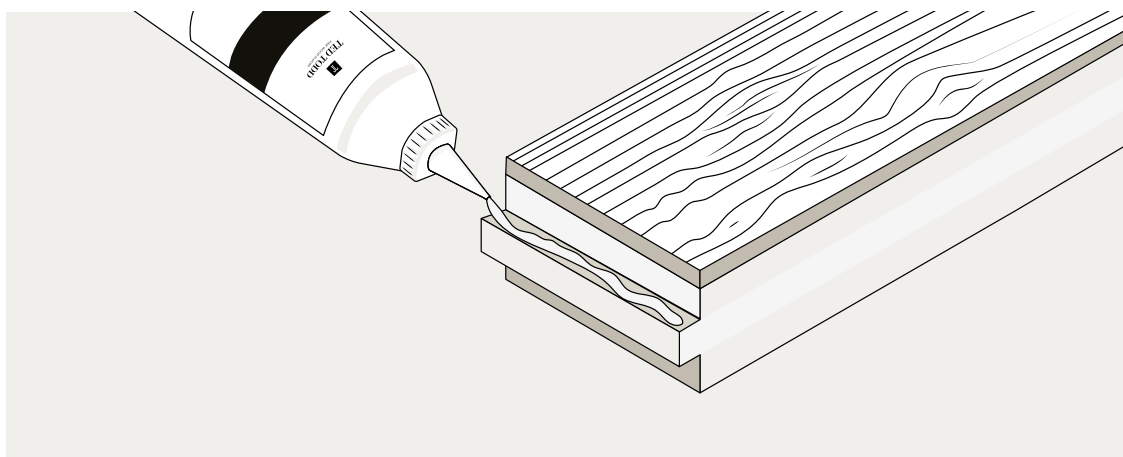

Figure 4: adhesive should be applied to the top of the T&G tongue.

Narrow Plank

Plank

Wide Plank

Extra-Wide Plank

Super-Wide Plank

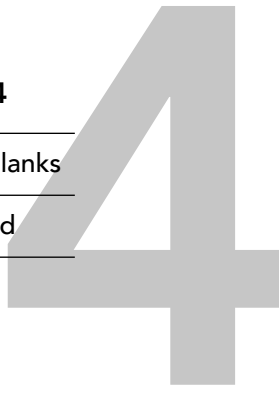

INSTALLATION OF: PLANKS - FLOATING

4.5.2 Click system planks.

- To float a click system floor, the procedure and guidelines are similar to those above, except for the application of the T&G adhesive.
- Follow the instructions carefully for guidance of how to click together the planks as different systems do vary.
- Careful attention must be paid to the maximum area of the installation which will depend upon the installation method.

4.6 Summary

- Site checks, site ready for wood floor
- Temperature and humidity
- Subfloor correctly prepared, clean, dry , flat and level.
- Maximum area (6m wide and 10m long) for Floating installation.
- Choice of Underlay.

4.7 FAQ's

Is all of the above really necessary?

The success of a good wood floor installation depends upon many factors. In instances where things go wrong, the problems will almost certainly be traceable back to failure to correctly follow some of the guidelines listed above. Even in apparently simple installation projects all of the above points must be checked to ensure compliance.

Why is there a maximum area limitation for floating a wood floor?

Wood floors change dimension with changes in humidity. In floating floor, the T&G of each piece will be tightly glued to the next. This means that the floor area as a whole will move as a single piece. In extreme cases the stress of this may cause joint failure and large gaps can appear between planks. (This is known as rafting).



Narrow Plank



Plank



Wide Plank



Extra-Wide Plank



Super-Wide Plank